

NOM DU PLAN
AXO. STRUCTURE
NOM DU PROJET
PERGOLA FONTAINE

MAITRE D'OUVRAGE
Mr KAOUCHE
ARCHITECTE

DATE
03.11.2024
DESSINATEUR
Mr MOREL

N° PROJET
N° PAGE
1 de 25
FORMAT
A4
ECHELLE
1:

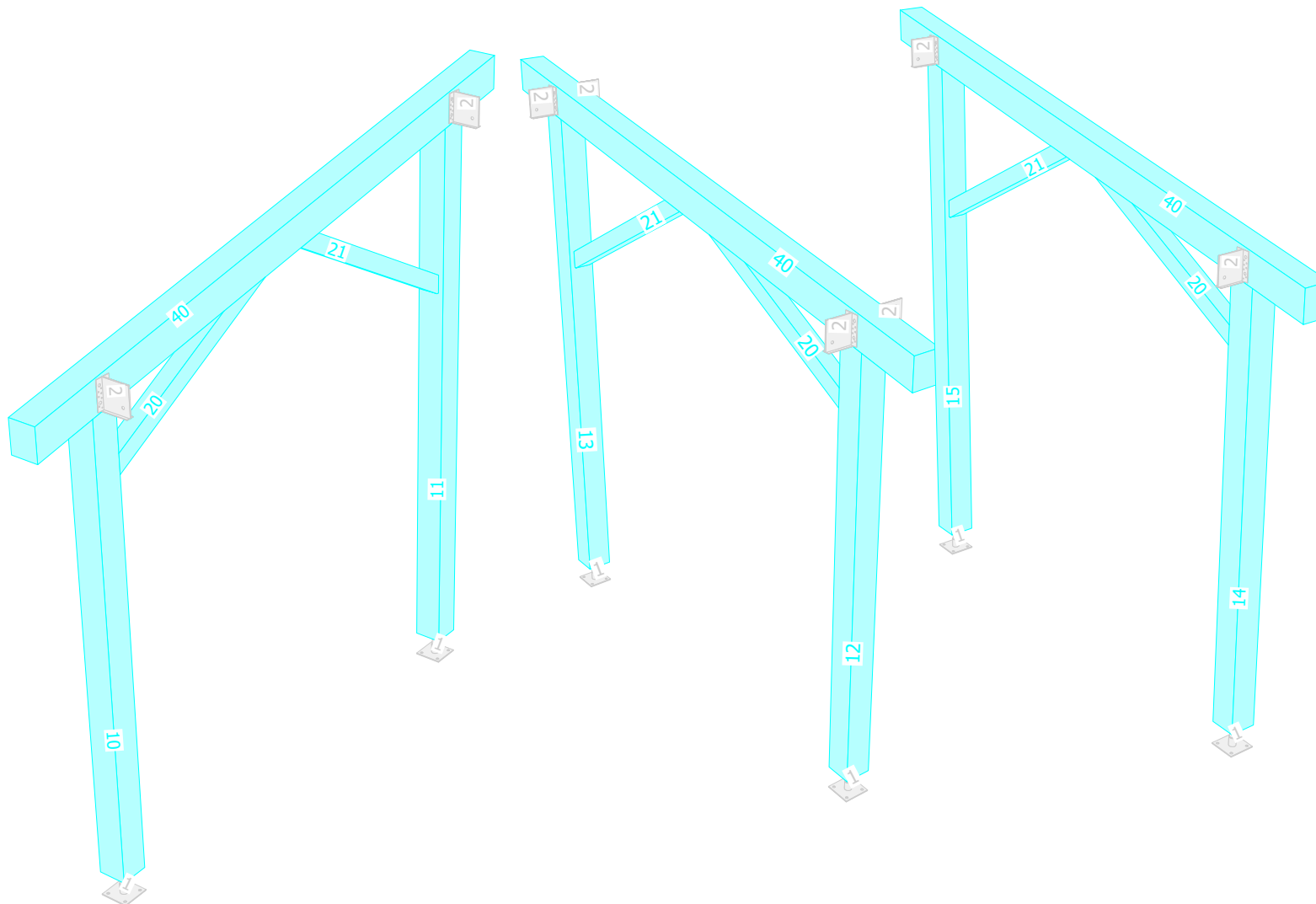

NOM DU PLAN

AXO. DETAIL FERRURE

NOM DU PROJET

PERGOLA FONTAINE

MAITRE D'OUVRAGE

Mr KAOUCHE

ARCHITECTE

DATE

03.11.2024

DESSINATEUR

Mr MOREL

N° PROJET

FORMAT
A4

N° PAGE

2 de 25

ECHELLE

1:

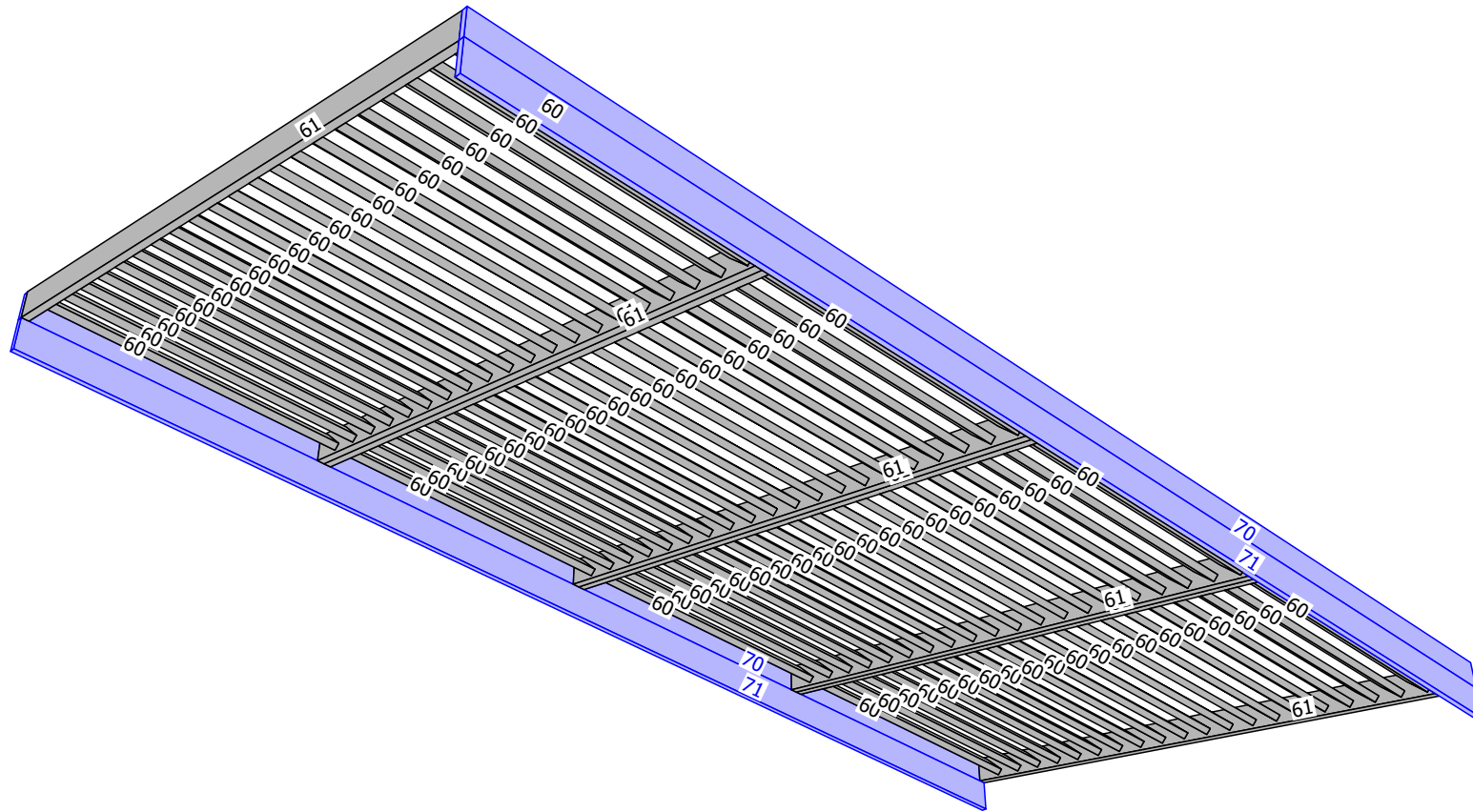

NOM DU PLAN

AXO. DETAIL BRISE SOLEIL

NOM DU PROJET
PERGOLA FONTAINE

MAITRE D'OUVRAGE

Mr KAOUCHE

ARCHITECTE

DATE

03.11.2024

DESSINATEUR

Mr MOREL

N° PROJET

FORMAT
A4

N° PAGE

3 de 25

EHELLE

1:

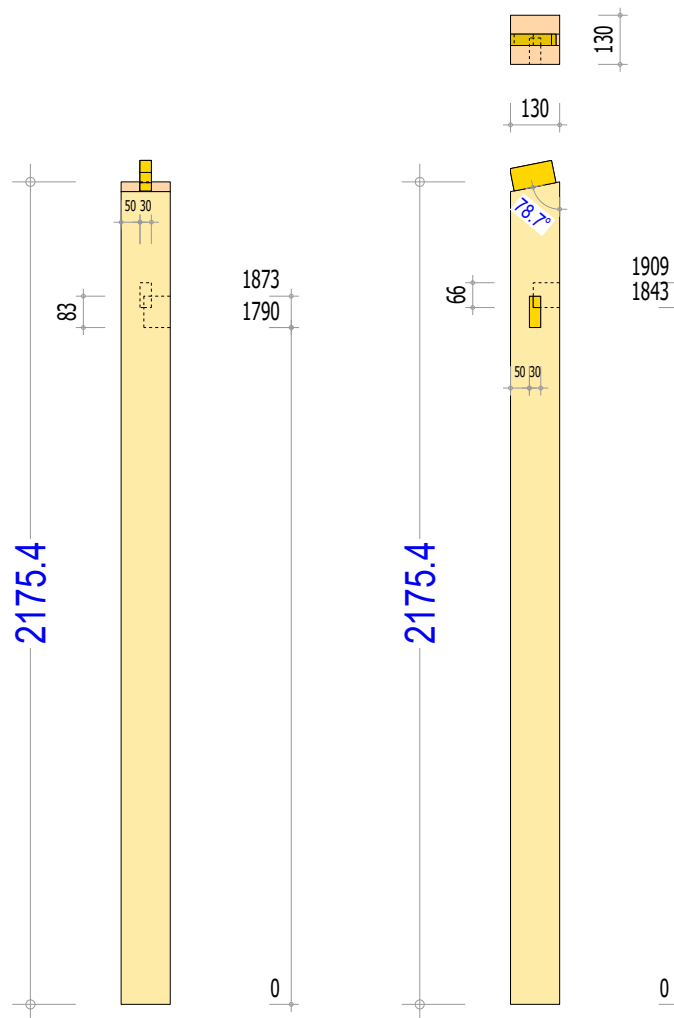

N° LP: **10**

Nom: **Poteau court exterieur**
 Type: Portique triangulé
 Sous-groupe:
 Matériaux: Douglas
 Quantité: **1**

Section: 130mm x 130mm
 Longueur: 2232.2mm
 Dimensions brutes: 130mmx130mmx2232.2mm
 Date: 03.11.2024
 Projet: Pergola_école_Ro
 Poids: 20,099 kg

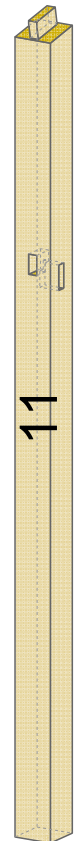
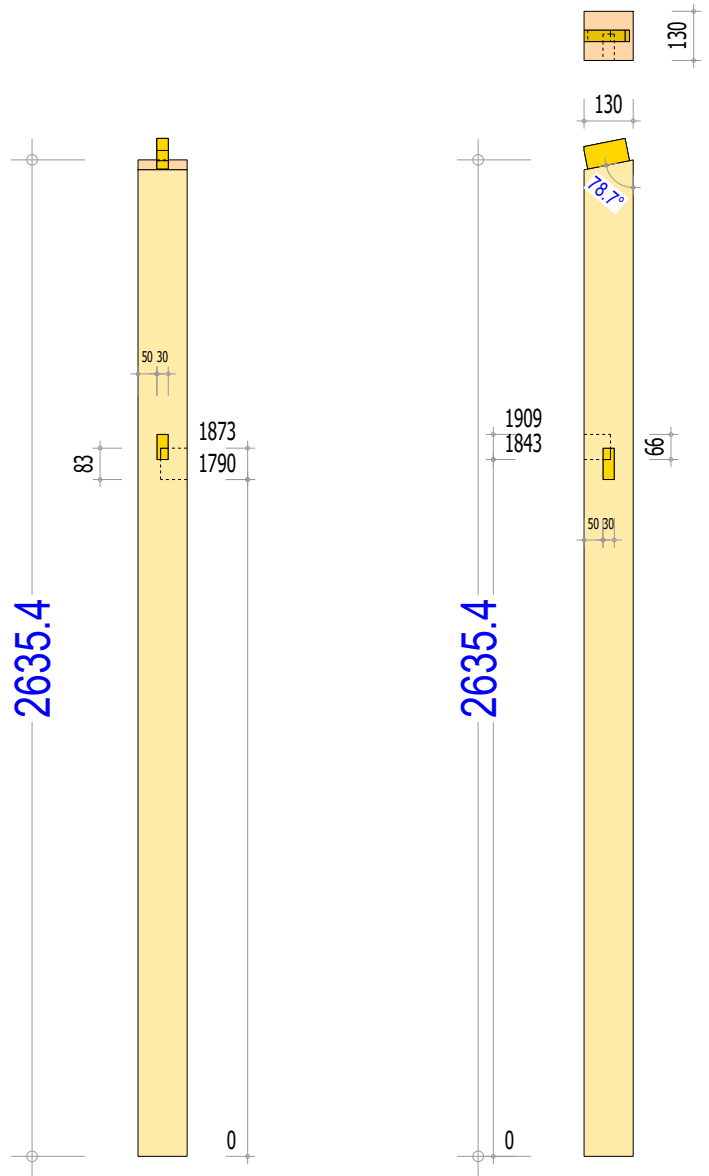

obespierre_Fontaine_01
 N° LP: **11**

Nom: **Poteau long exterieur**
 Groupe: Portique triangulé
 Sous-groupe:
 Matériaux: Douglas
 Quantité: **1**

Section: 130mm x 130mm
 Longueur: 2692.2mm
 Dimensions brutes: 130mmx130mmx2692.2mm
 Date: 03.11.2024
 Projet: Pergola_école_Ro
 Poids: 24,375 kg

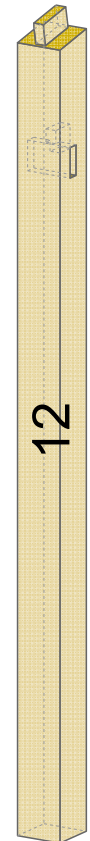
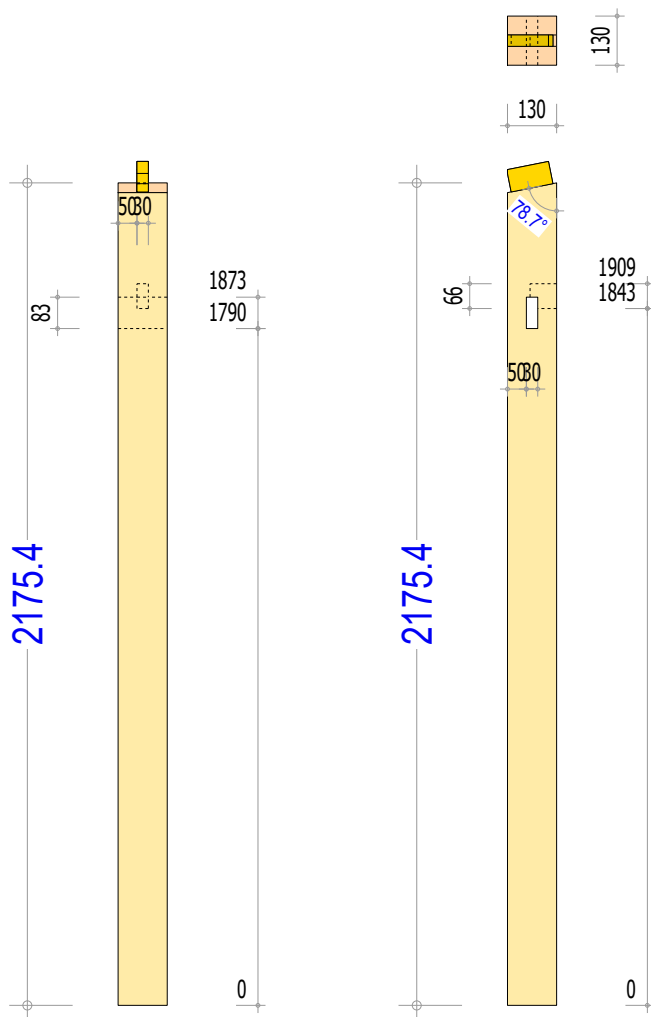

obespierre_Fontaine_01
 N° LP: **12**

Nom: **Poteau court inter**
 Sous-groupe: Portique triangulé
 Matériaux: Douglas
 Quantité: **1**

Section: 130mm x 130mm
 Longueur: 2232.2mm
 Dimensions brutes: 130mmx130mmx2232.2mm
 Date: 03.11.2024
 Projet: Pergola_école_Rc
 Poids: 20,099 kg

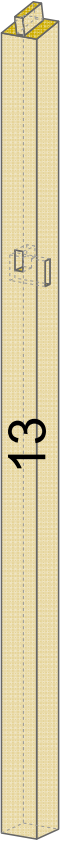
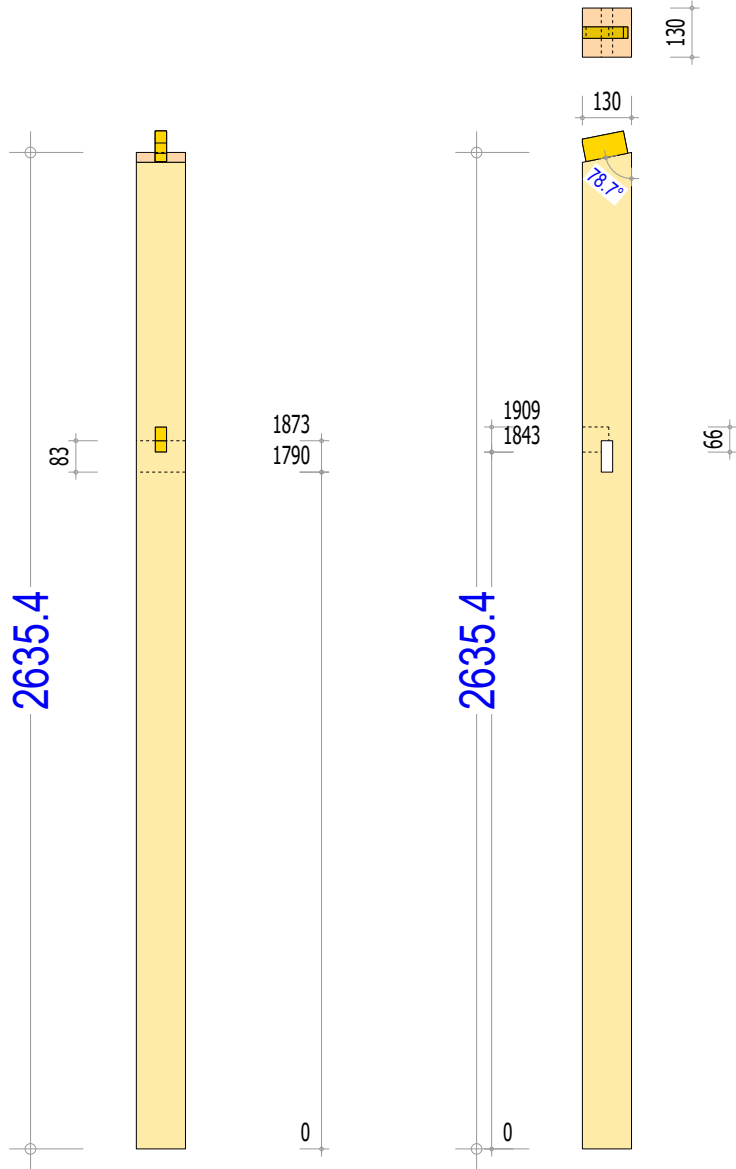

cadwork

obespierre_Fontaine_01
N° LP: **13**

Nom: **Poteau long inter**
Groupe: Portique triangulé
Sous-groupe:
Matériaux: Douglas
Quantité: **1**

Section: 130mm x 130mm
Date: 03.11.2024
Longueur: 2692.2mm
Projet: Pergola_école_Rc
Dimensions brutes: 130mmx130mmx2692.2mm
Poids: 24,375 kg

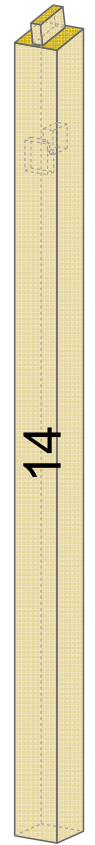
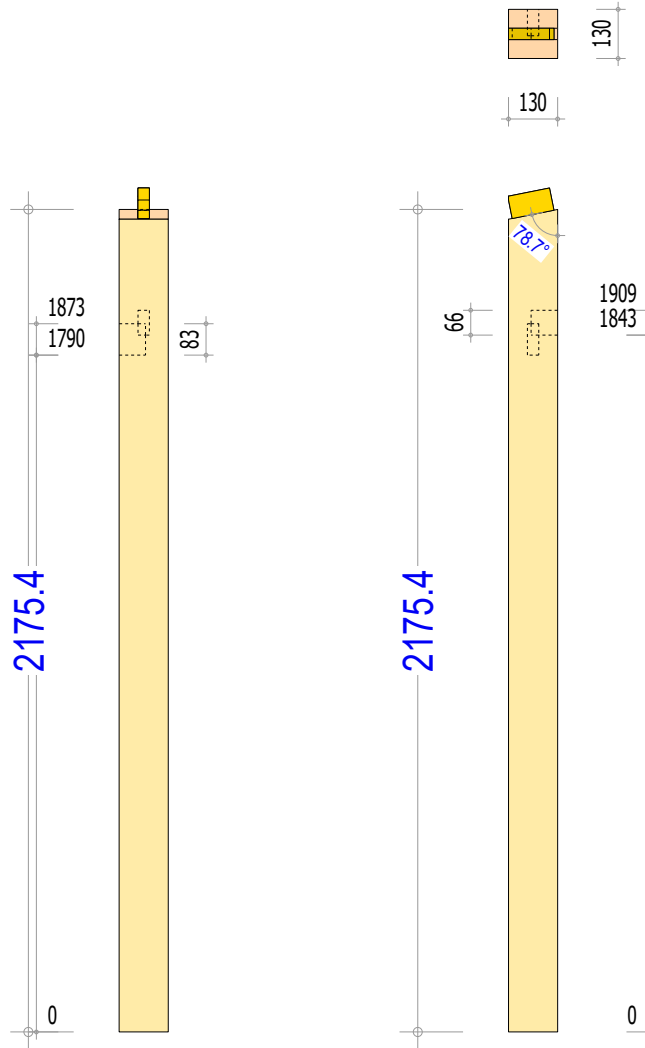

obespierre_Fontaine_01
 N° LP: **14**

Nom: **Poteau court exterieur**
 Type: Portique triangulé
 Sous-groupe:
 Matériaux: Douglas
 Quantité: **1**

Section: 130mm x 130mm
 Longueur: 2232.2mm
 Dimensions brutes: 130mmx130mmx2232.2mm
 Date: 03.11.2024
 Projet: Pergola_école_Ro
 Poids: 20,099 kg

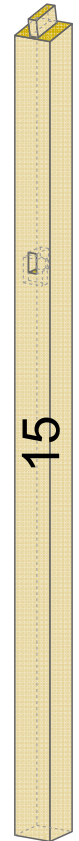
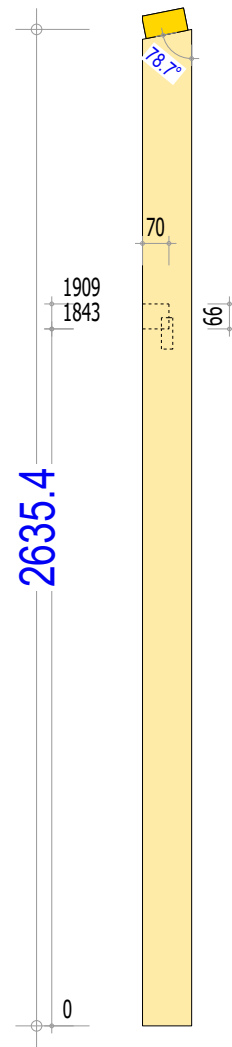
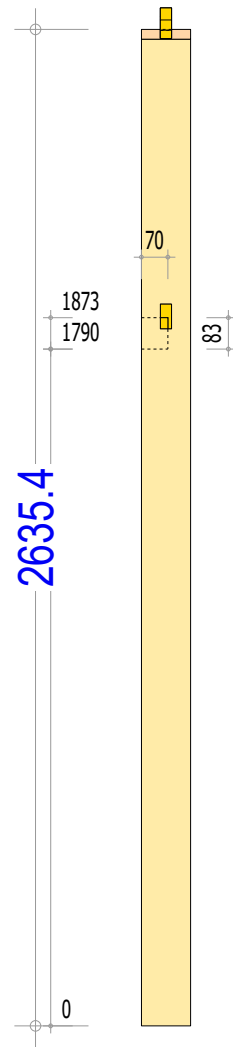
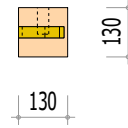

N° LP: **15**

Nom: **Poteau long exterieur**
Quantité: **1**
Sous-groupe: Portique triangulé
Matériaux: Douglas

Section: 130mm x 130mm
Longueur: 2692.2mm
Dimensions brutes: 130mmx130mmx2692.2mm
Date: 03.11.2024
Projet: Pergola_école_Ro
Poids: 24,375 kg

TENON 60x30mm + EPAUL SYM 10mm

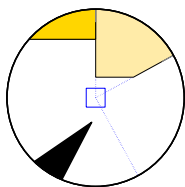

DESABOUT PERP. ARASE 10mm

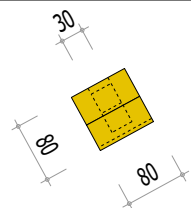
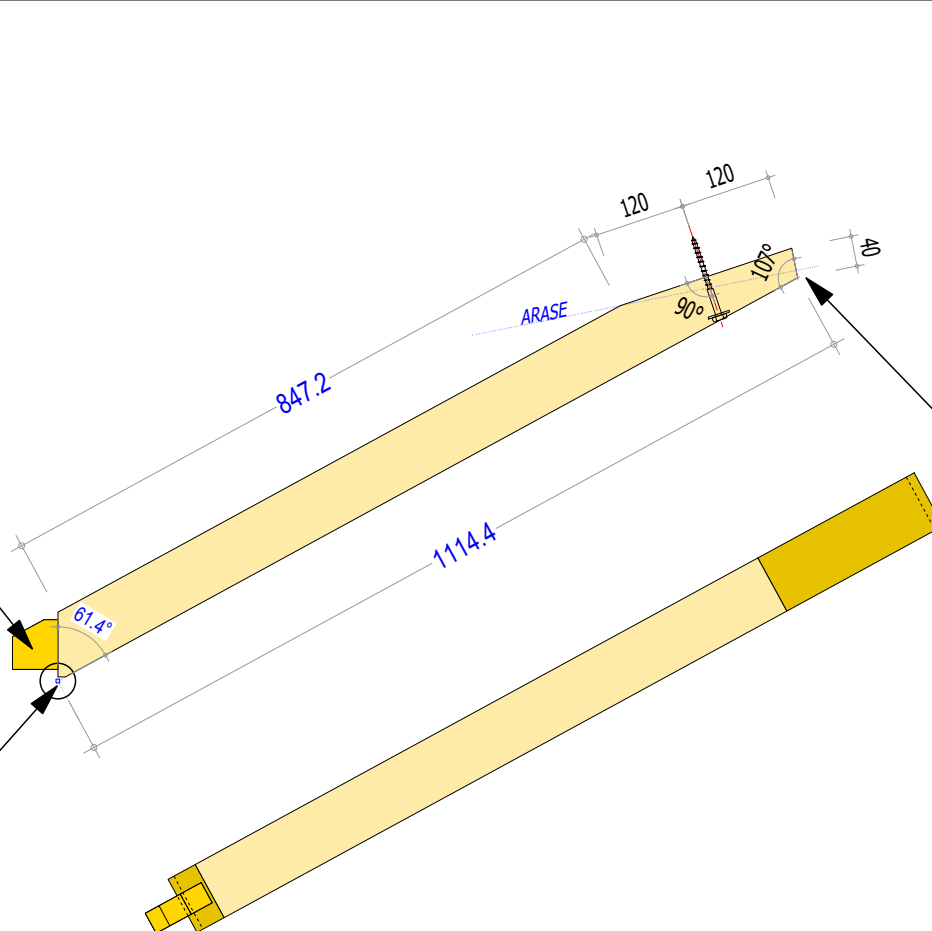

DESABOUT PERP. ARASE 10mm

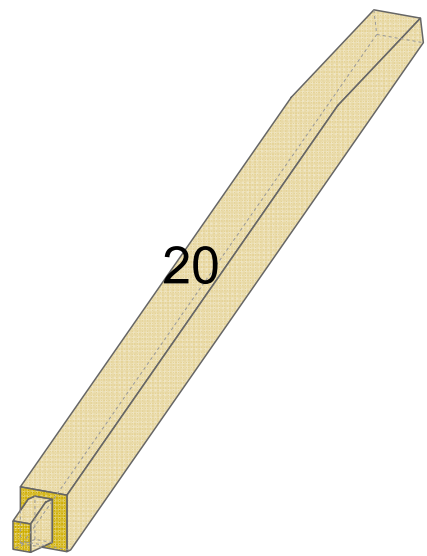

obespierre_Fo...
N° LP: **20**

Nom: **Contrefiche**
Quantité: **3**

Groupe: Portique triangulé
Sous-groupe:
Matériaux: Douglas

Section: 80mm x 80mm
Longueur: 1171.5mm
Dimensions brutes: 80mmx80mmx1171.5mm

Date: 03.11.2024
Projet: Pergola_écol...
Poids: 3,660 kg

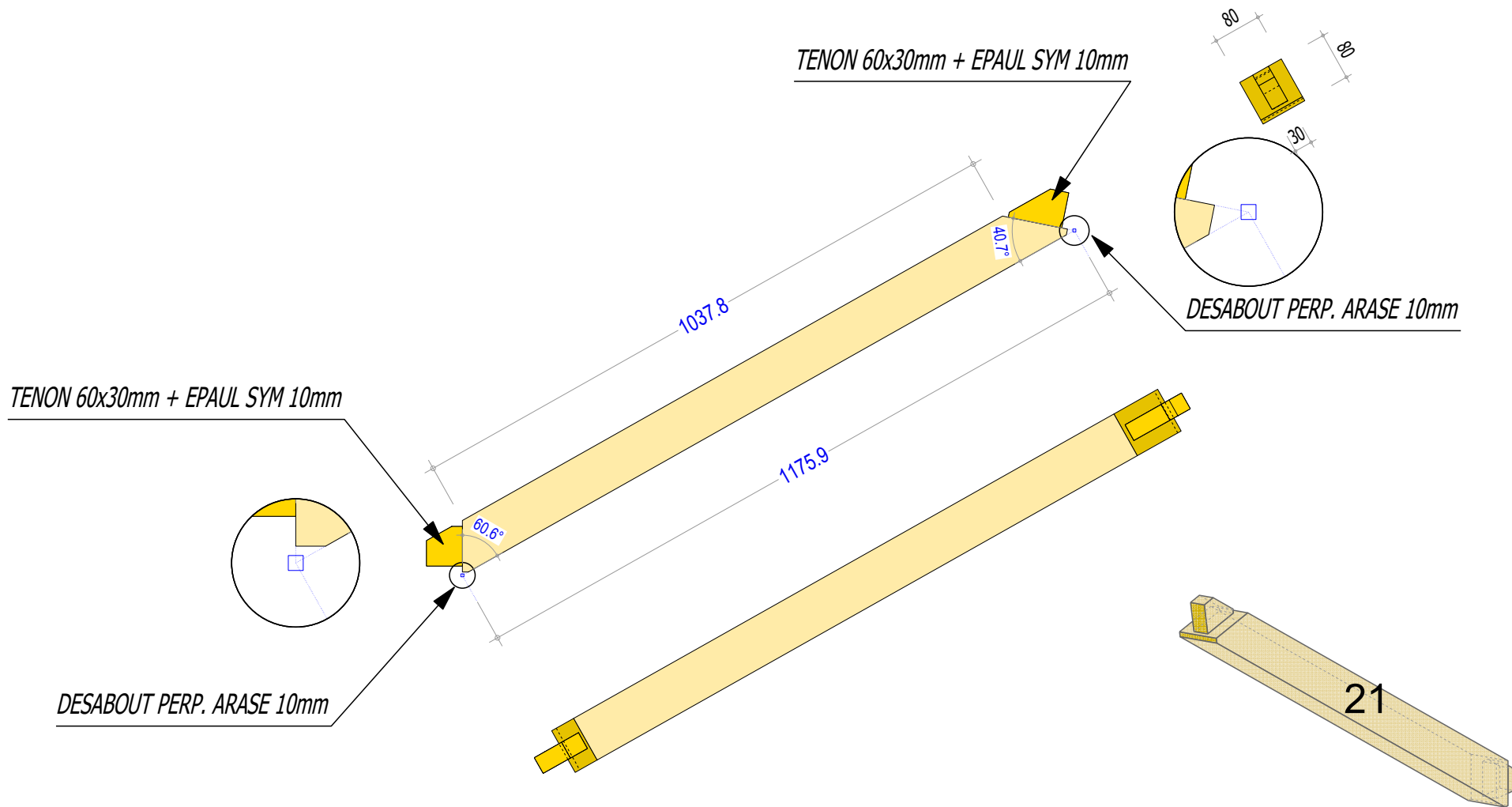

cadwork®

obespierre_Fontaine_01
N° LP: **21**

Nom: **Contrefiche**
Quantité: **3**

Groupe: Portique triangulé
Sous-groupe:
Matériaux: Douglas

Section: 80mm x 80mm
Longueur: 1243.2mm
Dimensions brutes: 80mmx80mmx1243.2mm
Date: 03.11.2024
Projet: Pergola_école_Rc
Poids: 3,892 kg

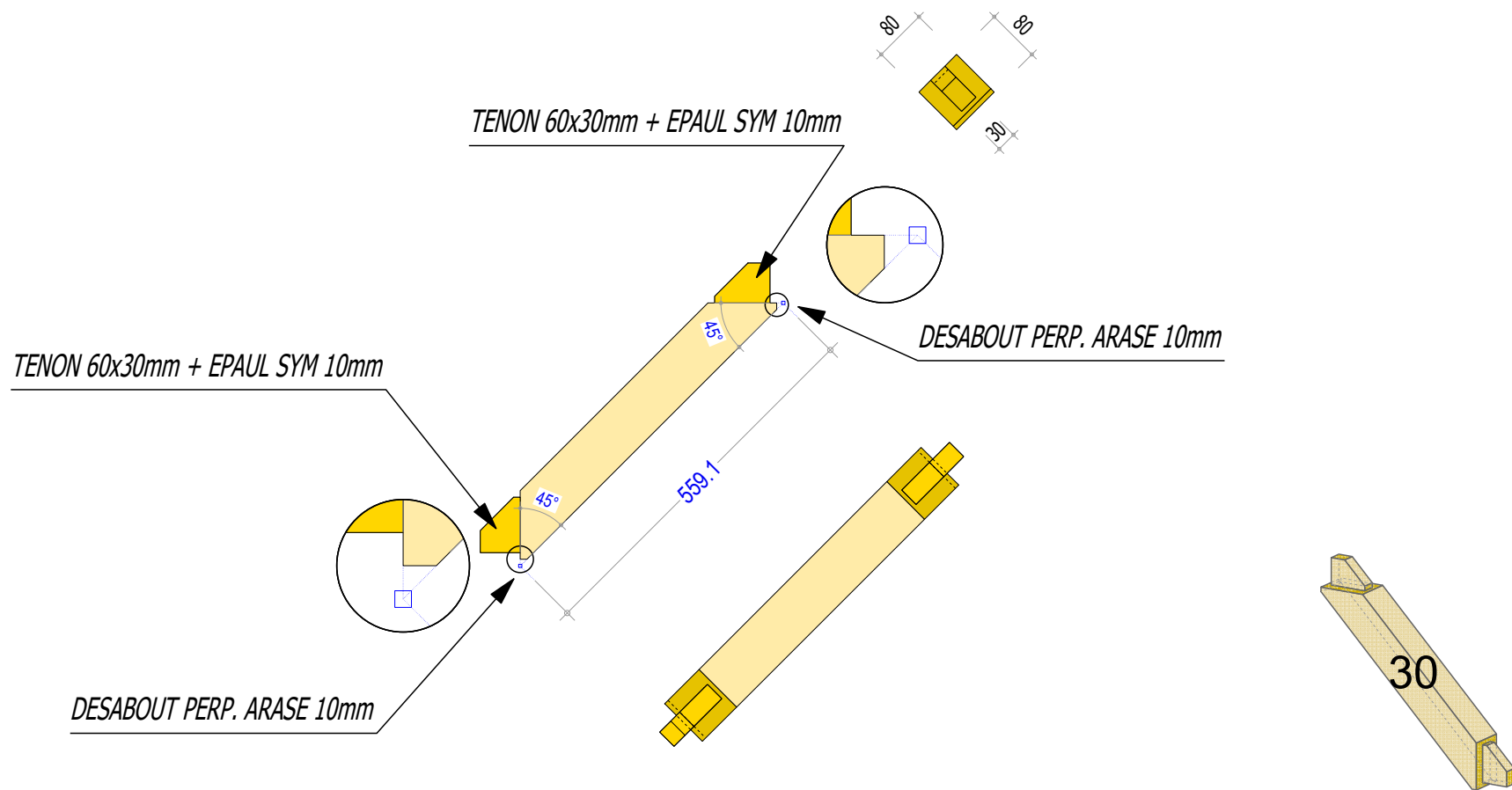

cadwork®

obespierre_F...ta...e_1
 N° LP: **30**

Nom: **Lien inf**
 Quantité: **4**

Groupe: Liens
 Sous-groupe:
 Matériaux: Douglas

Section: 80mm x 80mm
 Longueur: 615.6mm
 Dimensions brutes: 80mmx80mmx615.6mm
 Date: 03.11.2024
 Projet: Pergola_écol...
 Poids: 1,682 kg

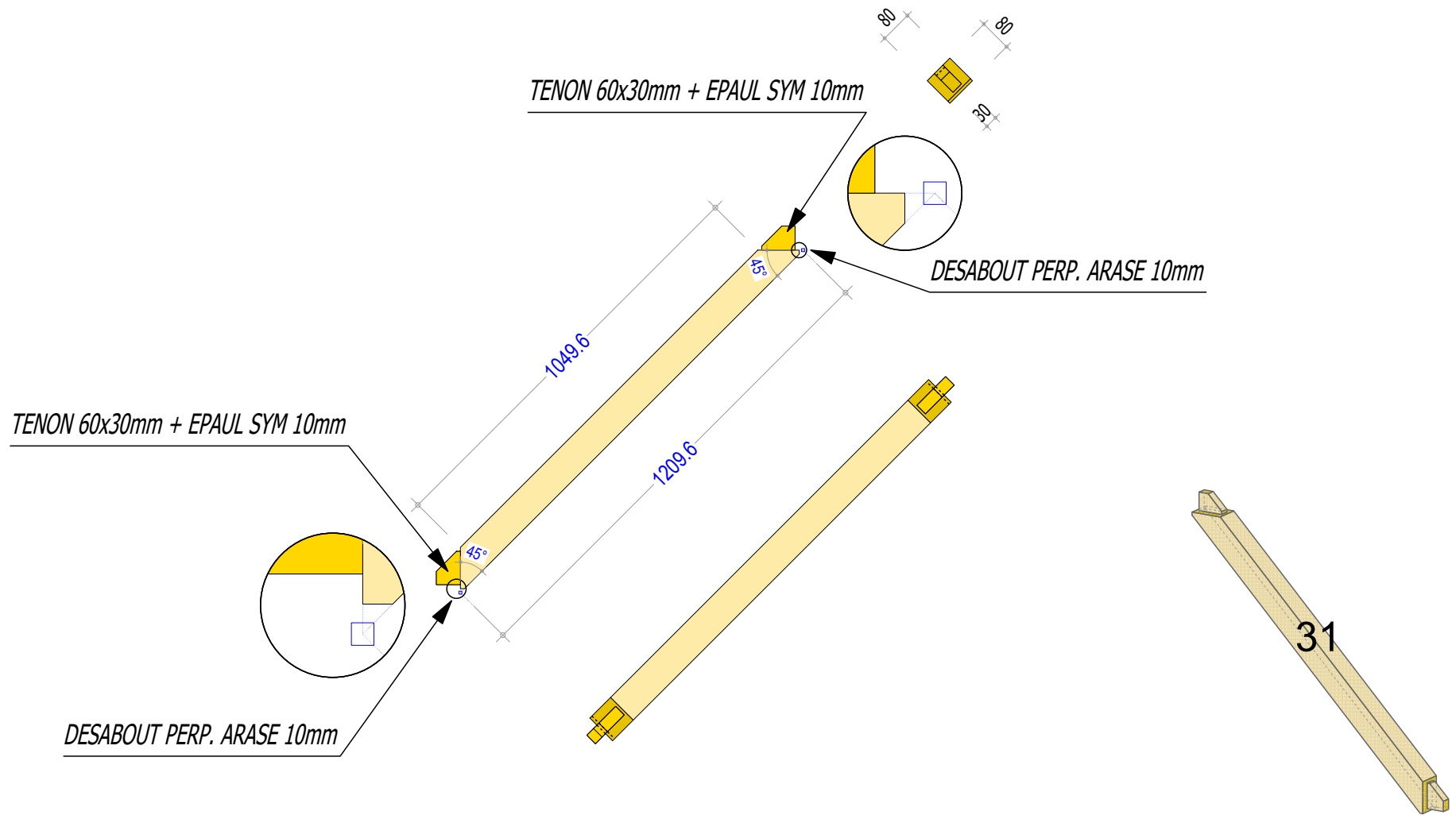

cadwork®

obespierre_Fontaine_01
N° LP: **31**

Nom: **Lien sup**
Quantité: **4**

Groupe: Liens
Sous-groupe:
Matériaux: Douglas

Section: 80mm x 80mm
Longueur: 1266.2mm
Dimensions brutes: 80mmx80mmx1266.2mm
Date: 03.11.2024
Projet: Pergola_école_Rc
Poids: 3,972 kg

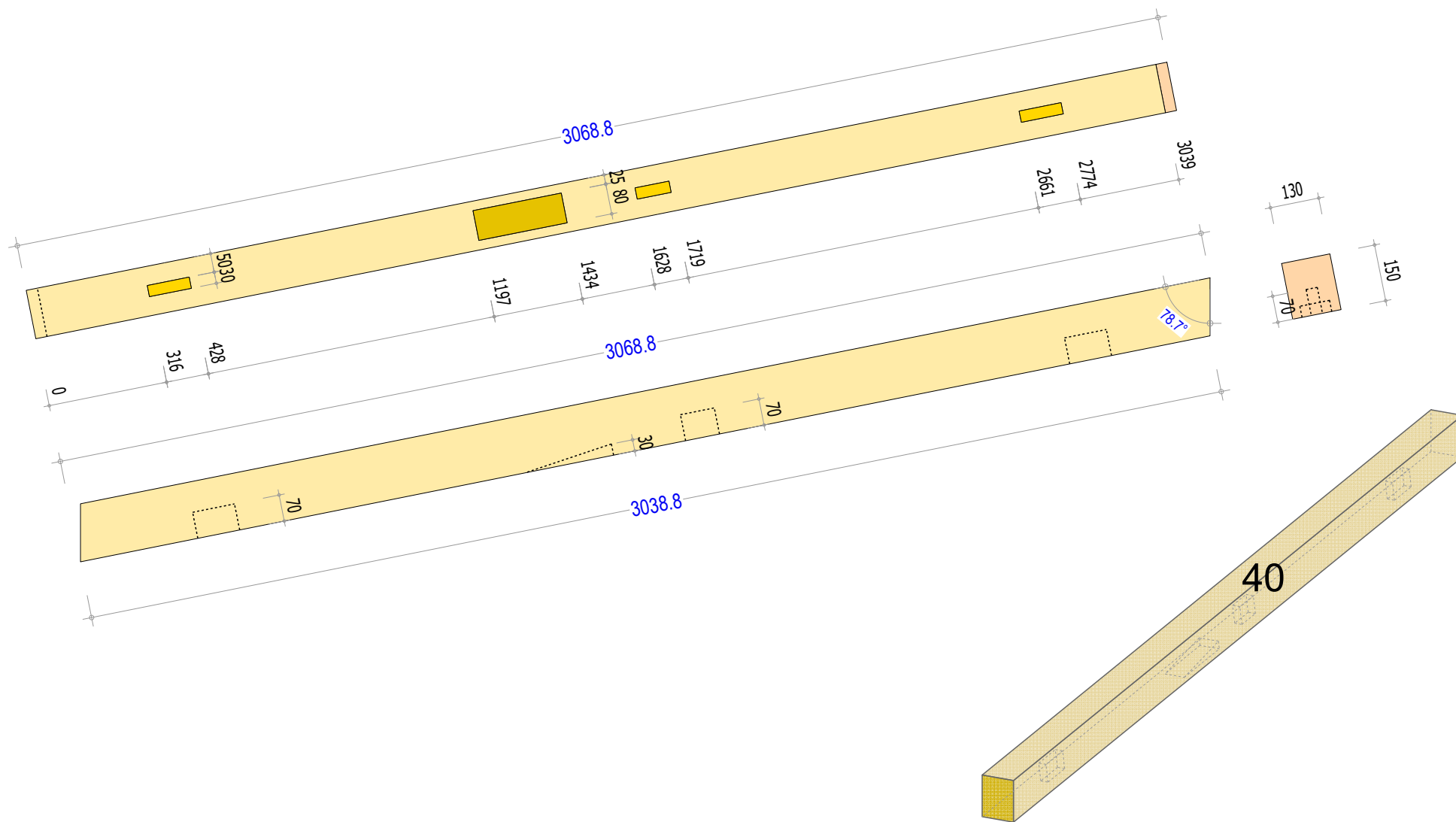

cadwork®

N° LP: **40**

Nom: **Arbalétrier**
Quantité: **3**

Groupe: Portique triangulé
Sous-groupe:
Matériaux: Douglas

Section: 130mm x 150mm
Longueur: 3068.8mm
Date: 03.11.2024
Projet: Pergola_école_Rc
Dimensions brutes: 130mmx150mmx3068.8mm
Poids: 32,435 kg

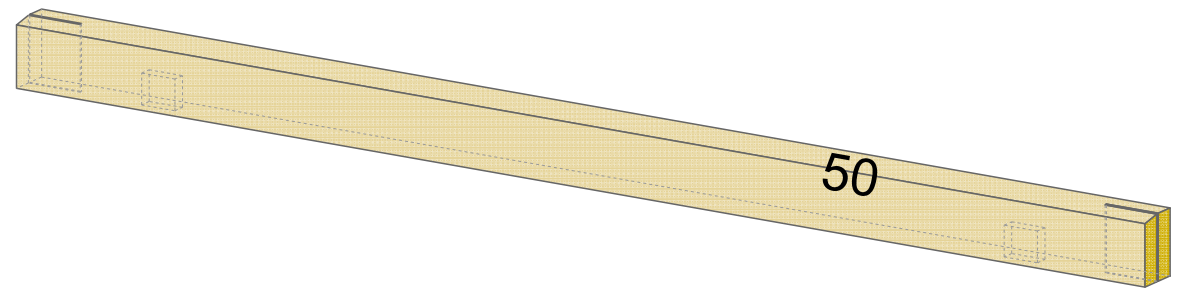
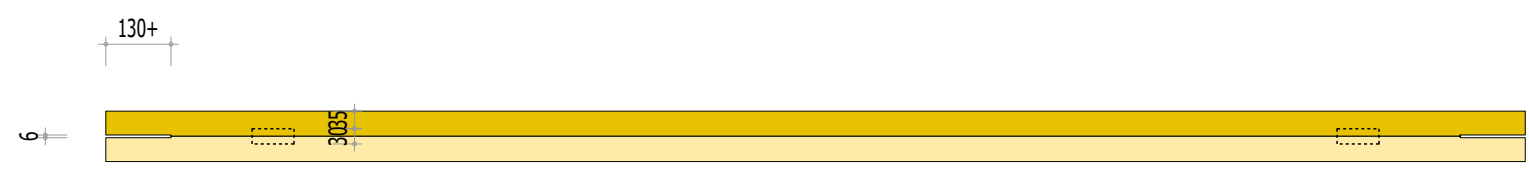
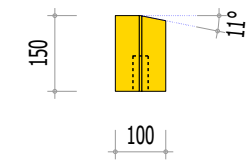
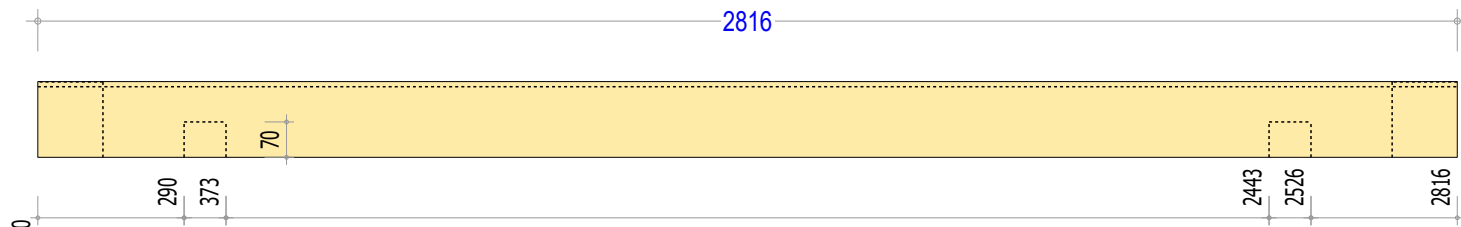

obespierre_01_tape_1
N° LP: 50

Nom: **Panne aplomb**
 Quantité: **4**
 Groupe: Panne
 Sous-groupe:
 Matériaux: Douglas

Section: 100mm x 150mm
 Longueur: 2816mm
 Dimensions brutes: 100mmx150mmx2816mm
 Date: 03.11.2024
 Projet: Pergola_école_Rc
 Poids: 22,728 kg

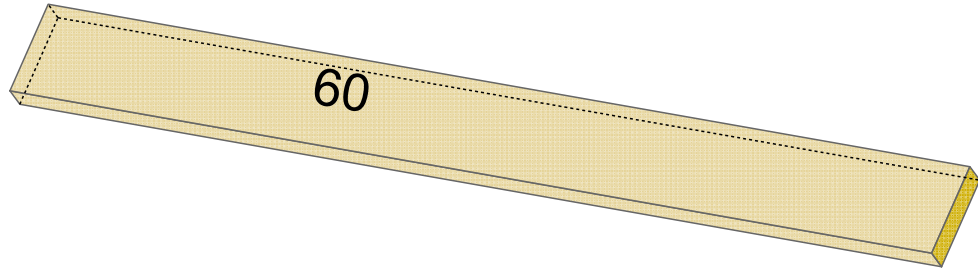
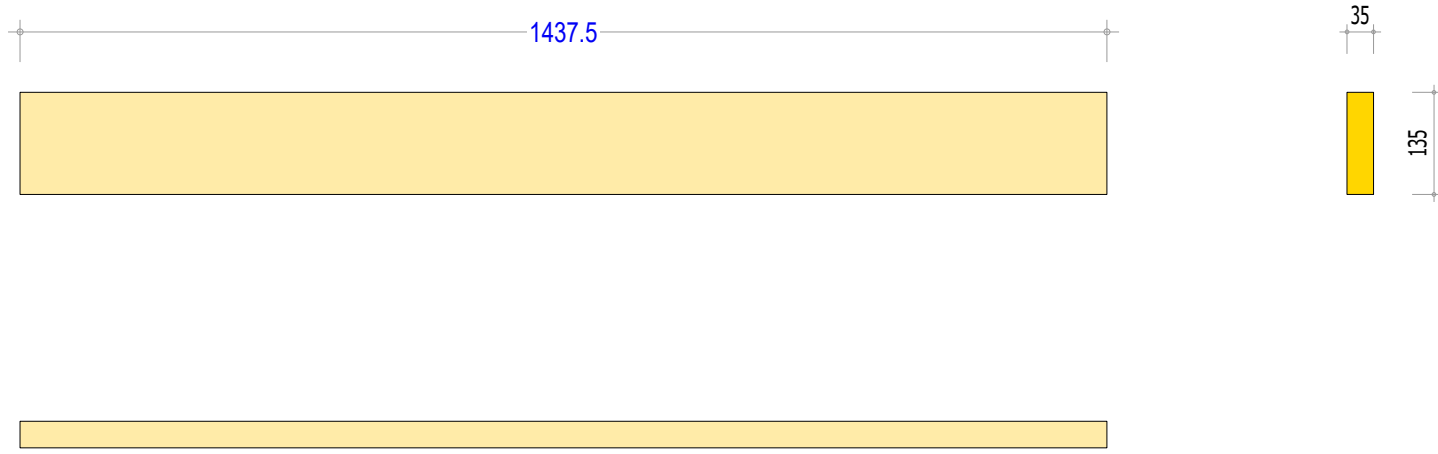

N° LP: **60**

Nom: **Latte**
Quantité: **84**

Groupe: Brise soleil
Sous-groupe:
Matériaux: Douglas

Section: 35mm x 135mm
Longueur: 1437.5mm
Dimensions brutes: 35mmx135mmx1437.5mm

Date: 03.11.2024
Projet: Pergola_école_Ro
Poids: 3,736 kg

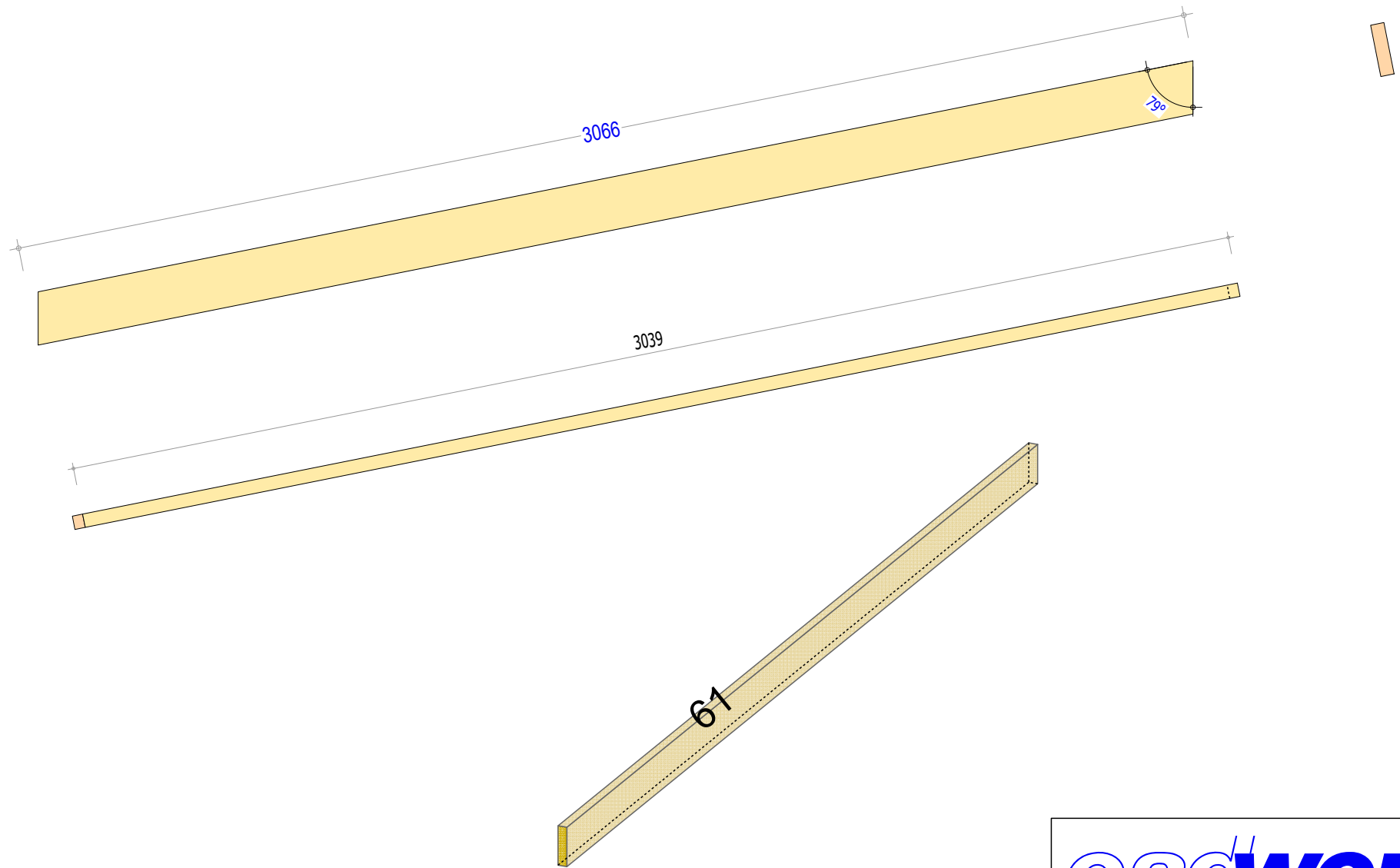

obespierre, taine 01
N° LP: **61**

Nom: **Ceinture**
Quantité: **8**

Groupe: Brise soleil
Sous-groupe:
Matériaux: Douglas

Section: 35mm x 135mm
Longueur: 3066mm
Dimensions brutes: 35mmx135mmx3066mm
Date: 03.11.2024
Projet: Pergola_école_Rc
Poids: 7,898 kg

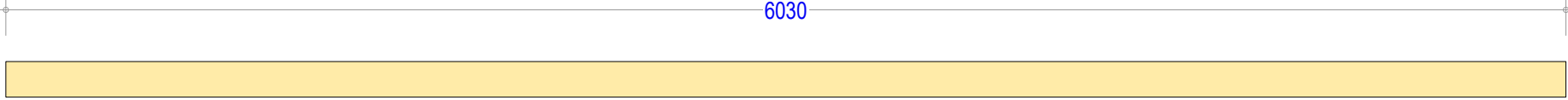

6030

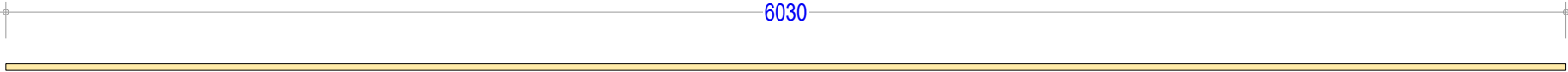

6030

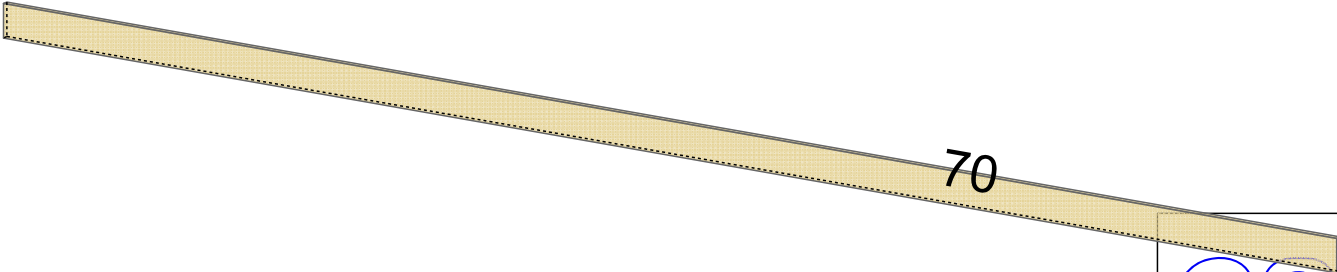

70

cadwork®

obespierre_Frontale_1
N° LP: **70**

Nom: **Rives**
2
Quantité:

Groupe: **Bandeau**
Sous-groupe:
Matériaux: **Douglas**

Section: **25mm x 137.7mm**
Longueur: **6030mm**
Dimensions brutes: **25mmx137.7mmx6030mm**

Date: **03.11.2024**
Projet: **Pergola_école_Ro**
Poids: **11,415 kg**

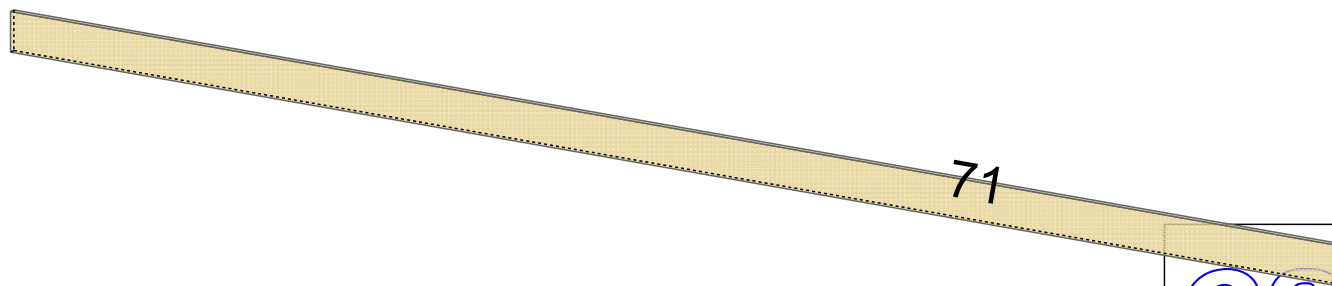
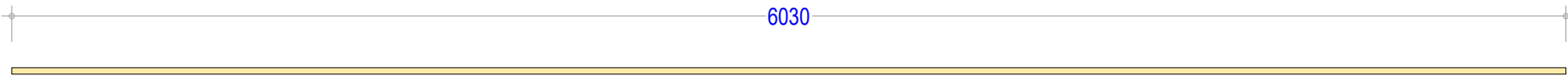
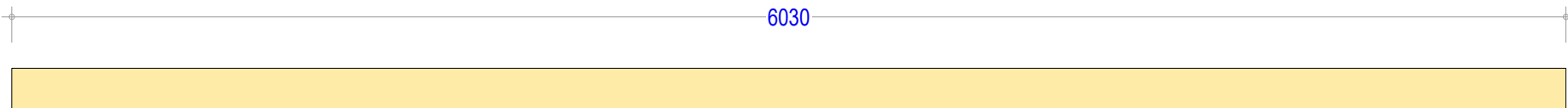

cadwork®

obespierre_Fontaine_01
N° LP: **71**

Nom: **Rives**
Quantité: **2**

Groupe: **Bandeau**
Sous-groupe:
Matériaux: **Douglas**

Section: **25mm x 162.3mm**
Longueur: **6030mm**
Dimensions brutes: **25mmx162.3mmx6030mm**
Date: **03.11.2024**
Projet: **Pergola_école_Rc**
Poids: **13,459 kg**

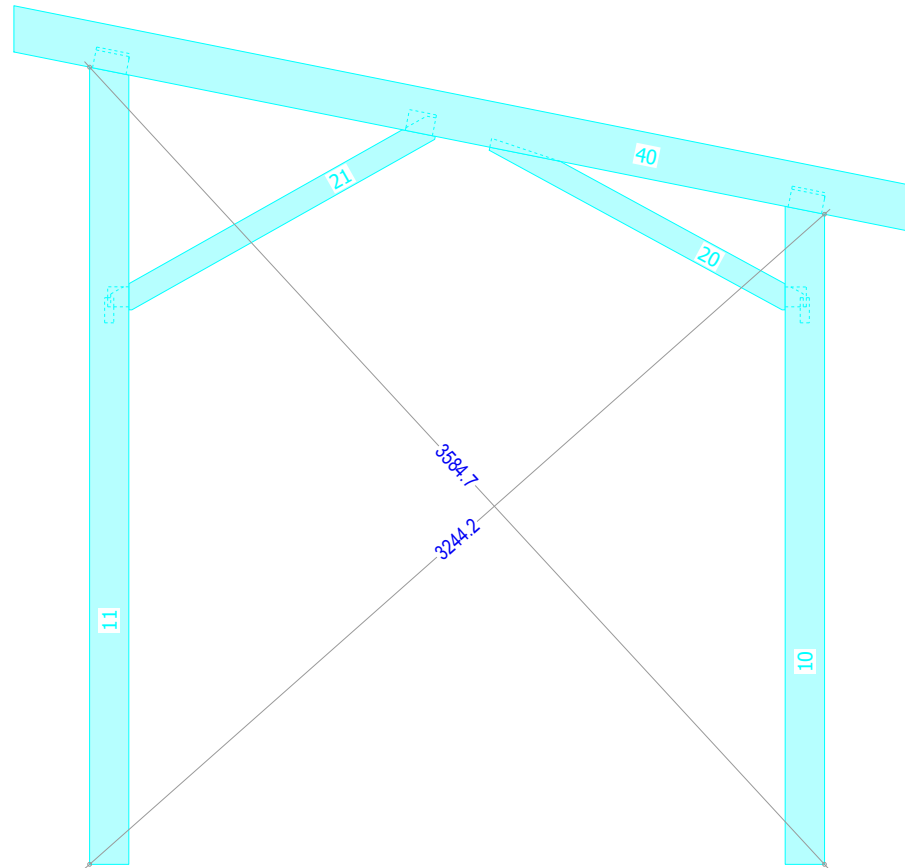

NOM DU PLAN

ELEV. PORTIQUE 10-11

NOM DU PROJET

PERGOLA FONTAINE

MAITRE D'OUVRAGE

Mr KAUCHE

ARCHITECTE

DATE

03.11.2024

DESSINATEUR

Mr MOREL

N° PROJET

FORMAT
A4

N° PAGE

21 de 25

ECHELLE

1:

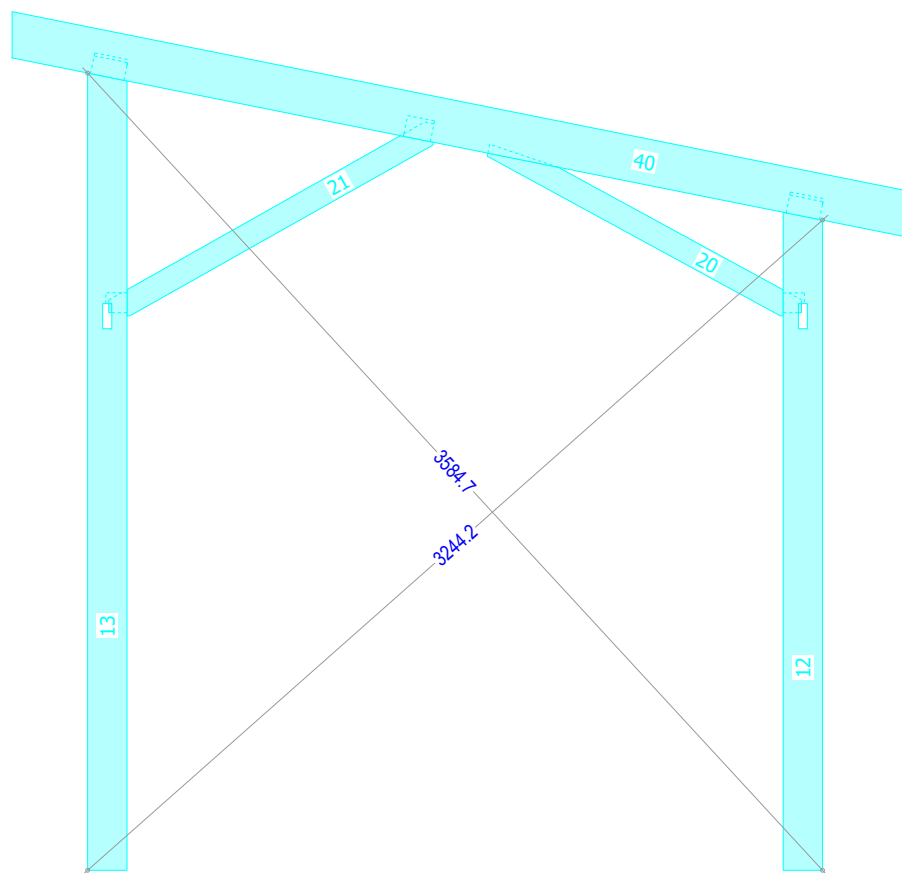

NOM DU PLAN

ELEV. PORTIQUE 12-13

NOM DU PROJET

PERGOLA FONTAINE

MAITRE D'OUVRAGE

Mr KAUCHE

ARCHITECTE

DATE

03.11.2024

DESSINATEUR

Mr MOREL

N° PROJET

FORMAT

A4

N° PAGE

22 de 25

ECHELLE

1:

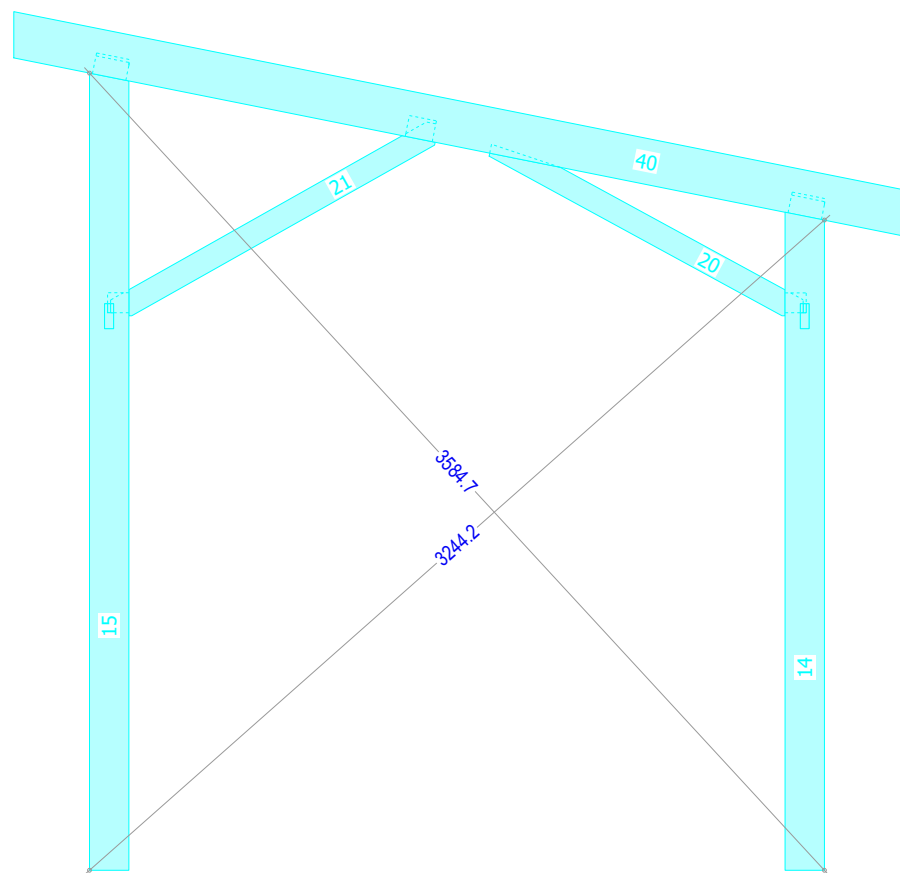

NOM DU PLAN

ELEV. PORTIQUE 14-15

NOM DU PROJET

PERGOLA FONTAINE

MAITRE D'OUVRAGE

Mr KAUCHE

ARCHITECTE

DATE

03.11.2024

DESSINATEUR

Mr MOREL

N° PROJET

FORMAT
A4

N° PAGE

23 de 25

ECHELLE

1:

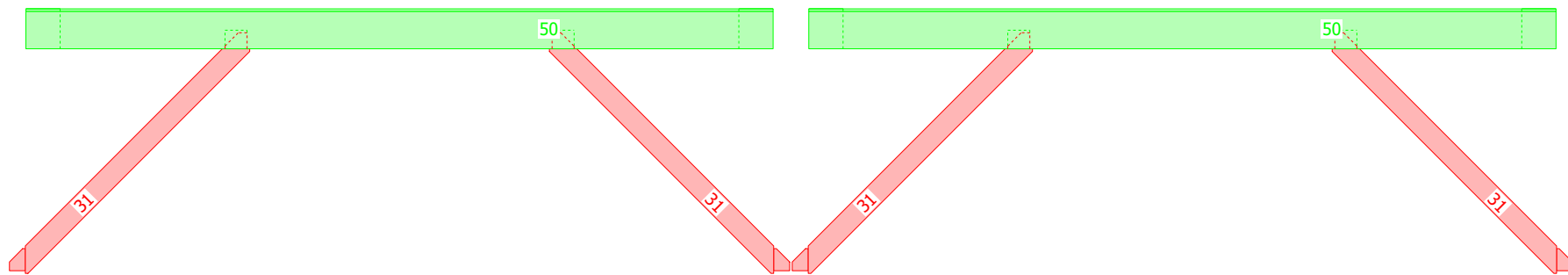

NOM DU PLAN

ELEV. PANNES H + LIENS

NOM DU PROJET

PERGOLA FONTAINE

MAITRE D'OUVRAGE

Mr KAOUCHE

ARCHITECTE

DATE

03.11.2024

DESSINATEUR

Mr MOREL

N° PROJET

FORMAT

A4

N° PAGE

24 de 25

ECHELLE

1:

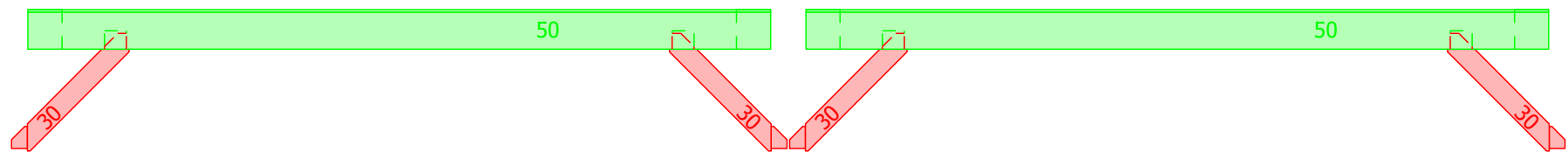

NOM DU PLAN

ELEV. PANNES B. + LIENS

NOM DU PROJET

PERGOLA FONTAINE

MAITRE D'OUVRAGE

Mr KAUCHE

ARCHITECTE

DATE

03.11.2024

DESSINATEUR

Mr MOREL

N° PROJET

FORMAT
A4

N° PAGE

25 de 25

ECHELLE

1:

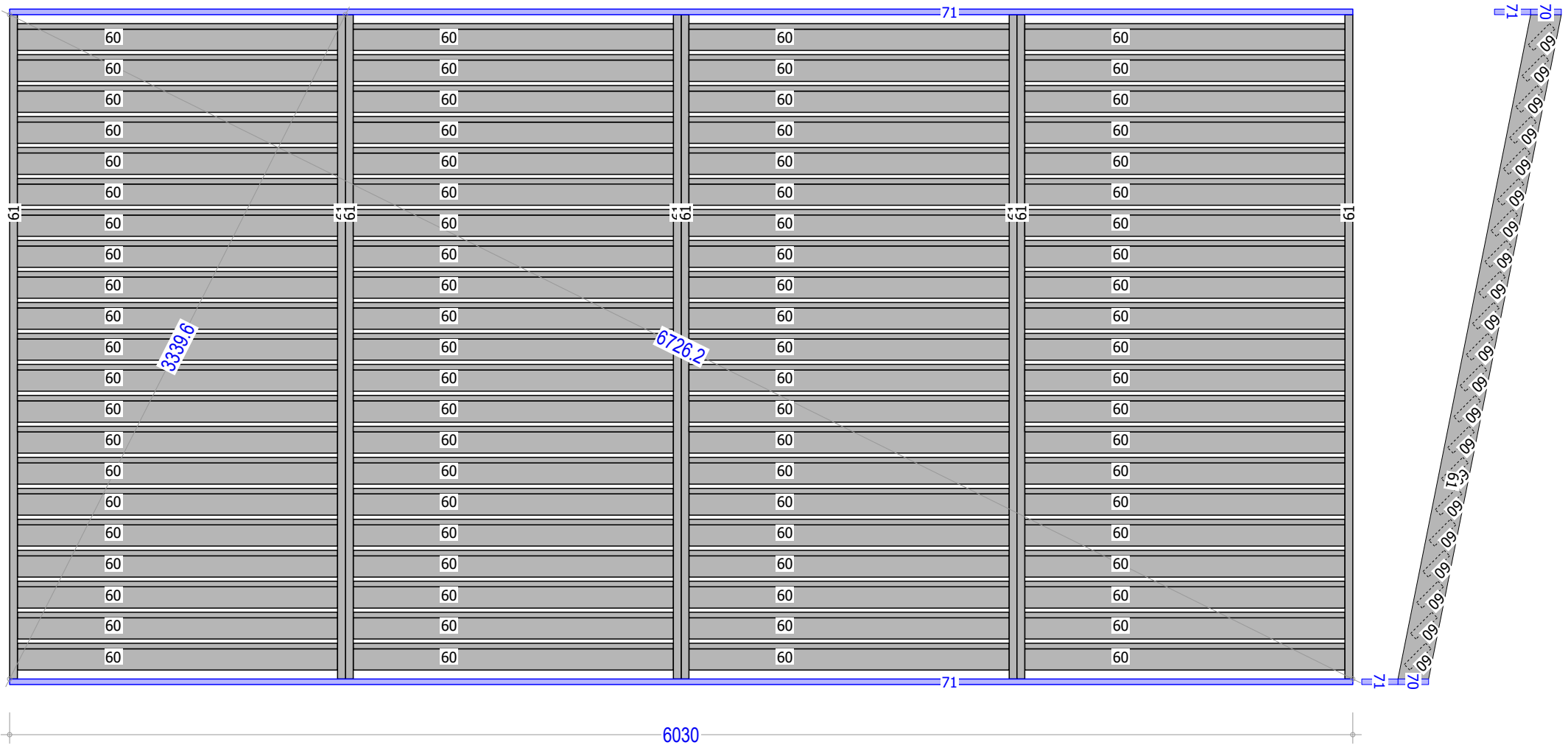

NOM DU PLAN
ENSEMBLE BRISE SOLEIL
 NOM DU PROJET
 PERGOLA FONTAINE

MAITRE D'OUVRAGE
 Mr KAOUCHE
 ARCHITECTE

DATE
 03.11.2024
 DESSINATEUR
 Mr MOREL

N° PROJET
 N° PAGE
 26 de 25
 FORMAT
 A4
 ECHELLE
 1: